

## Dimensions Continous Centrifugal

### Model DX, DX/HG

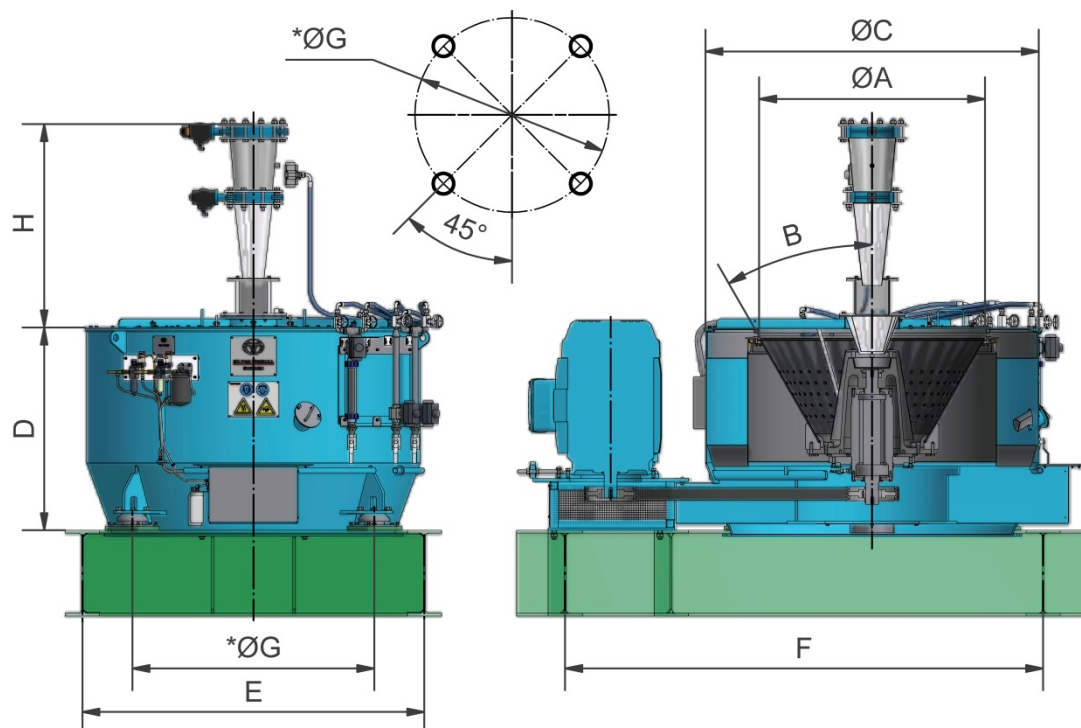

Model	A (mm)	B (°)	C (mm)	D (mm)	E, G (mm)	F (mm)	H (mm)	Screen area (m <sup>2</sup> )	Max speed (rpm)	Max purging force (G)	Power (kW/HP)
SW-1120DX	1120	30	1750	1110	1800	2600	1265	1,48	2100	2761	55/74
SW-1320DX	1320	30	1950	1185	2000	2795	1190	2,07	2000	2951	90/121
SW-1520DX	1520	30	2150	1357	2200	2995	1190	2,96	1800	2753	132/177
SW-1120DX/HG	1049	27	1750	1110	1800	2600	1265	1,37	2100	2598	55/74
SW-1320DX/HG	1247	27	1950	1185	2000	2795	1190	1,97	2000	2788	90/121

Model	Average Capacities			
	A-massecuite (t/h)	B-massecuite (t/h)	C-massecuite (t/h)	C-aff massecuite (t/h)
SW-1120DX	20-35	15-25	10-15	15-25
SW-1320DX	25-45	20-35	15-20	20-40
SW-1520DX	35-60	25-50	20-30	25-55
SW-1120DX/HG	25-40	20-30	n/a	n/a
SW-1320DX/HG	35-70	25-50	n/a	n/a

Note: The above numbers are based upon average capacities  
Actual capacity may vary depending upon local conditions and product desired.