

Dimensions Continous Centrifugal

Model D, D/HG

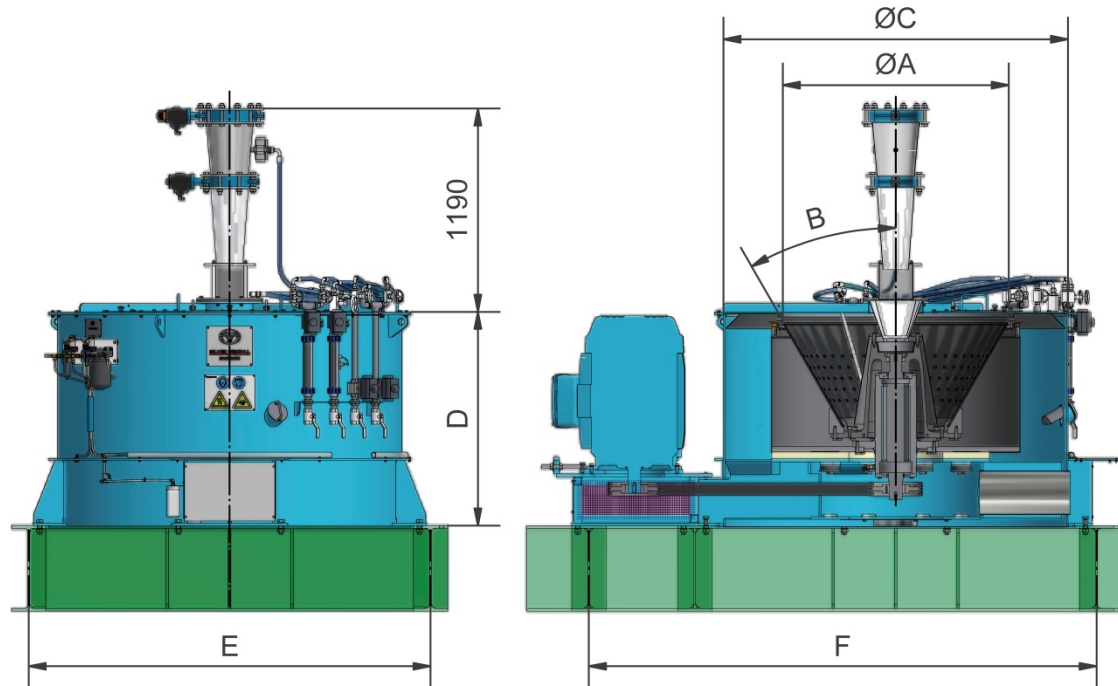

Model	A (mm)	B (°)	C (mm)	D (mm)	E (mm)	F (mm)	Screen area (m ²)	Max speed (rpm)	Max purging force (G)	Power (kW/HP)
SW-1320D	1320	30	2015	1250	2350	2970	2,07	2000	2951	90/120
SW-1520D	1520	30	2215	1422	2550	3170	2,96	1800	2753	132/180
SW-1320D/HG	1247	27	2015	1250	2350	2970	1,97	2000	2788	90/120

Model	Average Capacities			
	A-massecuite (t/h)	B-massecuite (t/h)	C-massecuite (t/h)	C-aff massecuite (t/h)
SW-1320D	25-45	20-35	15-20	20-40
SW-1520D	35-60	25-50	20-30	25-55
SW-1320D/HG	35-70	25-50	n/a	n/a

Note: The above numbers are based upon average capacities
Actual capacity may vary depending upon local conditions and product desired.